

SCANROOF

INSTALLATION MANUAL



Comparative Table of Attributes

ITEMS	SCANROOF	CONCRETE ROOF
1. Price	Cheaper when the roof framework is included	More expensive with more roof framework
2. Slope of the roof	Not less than 12 degree	Not less than 15 degree
3. Weight	6.3 kg. / square meter	49 kg. / square meter
4. Foundation	Using less pile and foundation	Using more pile and foundation
5. Roof framework	Saving more framework because of built-in purlin and its lightness	Using much more purlin and framework
6. Heat	More capable of reflecting the heat which will make a cooler temperature in the evening	Less capable of reflecting the heat, so the accumulated heat can be felt even in the evening
7. Noise during rainfall	A little louder but barely noticeable because of other louder noises	A little quieter but barely noticeable because of other louder noises
8. Installation	Easy to install, time and labor-saving, and having strength/resistance against wind force	Consume more time and labor in installation, the roofing artisan often neglects the fastening of roof tiles
9. Transportation	With light weight, it is cheaper when being transported and barely been damaged during transportation	Causing more expense in transportation and being much exposed to damage
10. Rainproof capability	More capable of rain-proof with fewer and finer joints	Having frequent problems of leakage
11. Maintenance required	Rarely happened	More maintenance is required
12. Endurance	More than 15 years	Beginning to crack after the fifth year
13. consistency of color	Equal color and size in every lot	Inconsistent in sizes and colors
14. Harmfulness to health	Nothing	Being harmful if the roof-piece is full of fungus or its color erodes

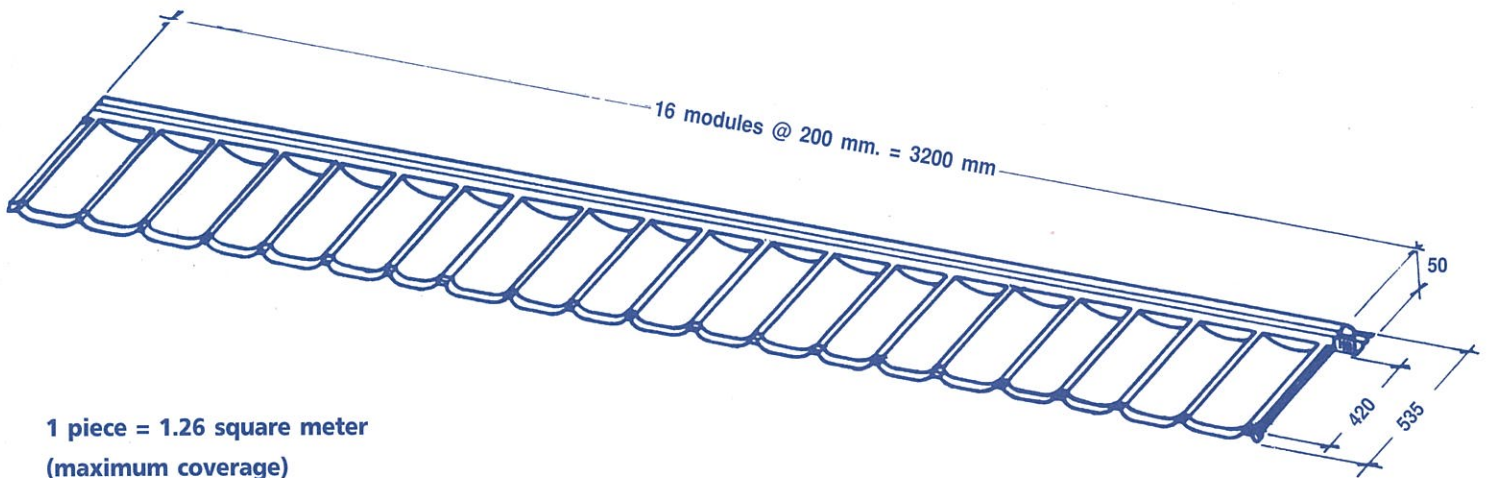

1 piece = 1.26 square meter
(maximum coverage)

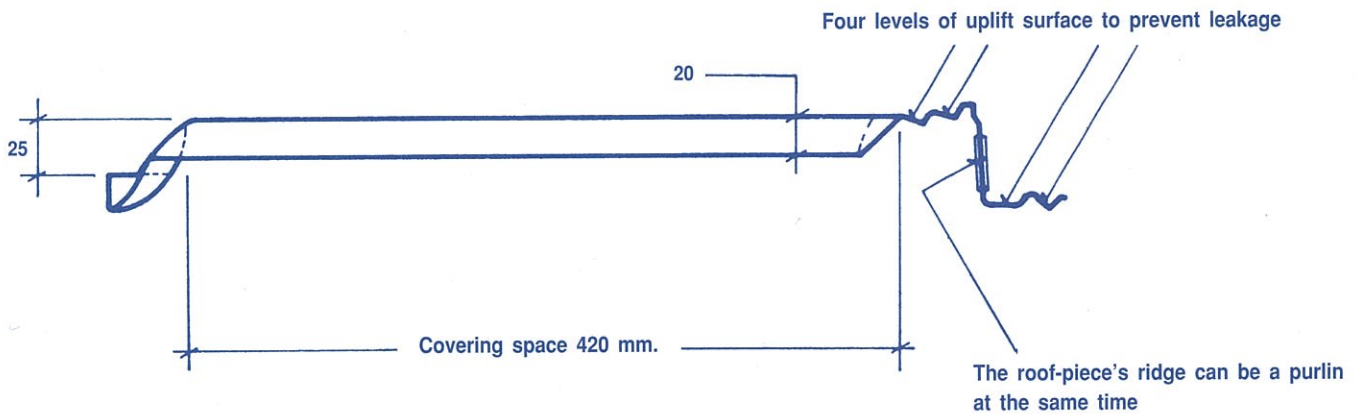

Iron roof structure of the rafter

RAFTER'S LENGTH (m.)	SPAN BETWEEN RAFTERS 1.50 m. OR LESS	WEIGHT (kg/m.)
3.00	C 75 x 45 x 15 x 2.3	3.25
	Ø 75 x 2.3	4.06
3.50	C 100 x 50 x 20 x 2.0	3.56
	Ø 75 x 3.2	5.50
4.00	C 100 x 50 x 20 x 2.3	4.06
	Ø 100 x 2.3	5.14
4.50	C 125 x 50 x 20 x 3.2	4.51
	Ø 100 x 3.2	7.01
5.00	C 150 x 50 x 20 x 3.25	6.13
	Ø 125 x 2.3	6.96
5.50	C 150 x 50 x 20 x 3.2	6.76
	Ø 125 x 3.2	9.52
6.00	C 150 x 65 x 20 x 3.2	8.01
	Ø 150 x 3.2	10.80
6.50	C 150 x 65 x 20 x 3.2	10.20
	Ø 150 x 4.5	14.90

- Note :**
1. Choose the size of rafter as per mentioned.
 2. Paint the rust-guard color at least 2 times.
 3. Clean every welding joint and paint the rust-guard color 2 times.
 4. No purlin is required

SPECIFICATION

MATERIAL

Thickness of the base metal	0.50 mm.
Yield strength of base metal	28 kg.(force)/sq.mm.

ROOF FRAMEWORK

Space between rafters	not more than 1,500 mm.
Space between purlin	purlin is not be required, except the lowest row

ROOF-PIECE FASTENING

Fastened by self-drill screw	GSP 14-14 x 20
------------------------------	----------------

SLOPE OF THE ROOF

Angle of the roof	minimum 12 degree
-------------------	-------------------

DIMENSION

Width	535 mm.
Effective width when installed	420 mm. max. (The overlapping of each row can be adjusted from 270-420 mm.)
Length	3,200 mm.
Effective width when installed	3,000 mm.
Horizontal overlapping space	200 mm. (1 wave)
Overlapping space in the roof's slope	270-420 mm. (adjustable)
Weight for 1 piece with 3,200 mm. of length	8.10 kg.
Weight for 1 square meter	6.30 kg.

NOISE AND HEAT

Noise happened when the rain is dropping on the roof

Generally, the noise of rain dropping on the metal roof is a little louder than that made by the concrete or tile roof and rather unnoticeable.

From an experiment done by University of Technology in Lulea, Sweden, it was found that the loudness of rain dropping noise on a roof of SCANROOF has the value about 40 dB (decibel) while the sound of rain on the concrete roof about 10 dB (decibel). The value of 40 dB (decibel) is as loud as the noise from automobile sneaking into the house with all its doors

and windows shut, while even the voice of people talking 1 meter away can reach 50 dB (decibel) or the working vacuum dust sucker can bear 80 dB (decibel).

In fact, when it is raining, the noises made by other things, say, the road or the garbage bin, is much louder than that of the roof, We mainly perceives these sounds and do not even notice about the existence of rain dropping on the rooftop, in the other words, we can hardly figure out that our roof is made by metal or concrete.

Heat

It is a long-established notion that the heat entering a house come mainly through the roof. This is a complete fallacy, for all the heat comes through the following sources :

1. Direct solar heat that shines toward both the wall and roof. The heat comes mainly through the wall, for the space between the roof and ceiling or within the roof framework is capable of removing the heat.

2. Heat from the house's constructing materials - we found that any material that is less capable in absorbing the heat (or reflecting more heat) will cause the lower temperature in a house than that with more capability. For instance the house with its wall made of wood will absorbed less heat and provide the cooler feeling than a house made of brick (the proof can be done by touching the wall that stands against the sunlight, you can feel the warmth, even when the sun is completely disappeared).

3. Heat radiated or reflected from nearby

substance or building such as the heat from its wall and reflecting mirror (building).

4. Heat brought by the wind - this is because the wind blows through the hot area such as street or fence.

Briefly, the heat that reaches a house mainly comes from other source while those caused by the roof is just a little ; especially the roof framework and ceiling are good insulators of the heat caused by metal roof which is much less capable of absorbing the heat than concrete roof.

We found that the solar heat shine toward the metal roof will be reflected more than the reflection from the concrete roof, so the heat that is absorbed will be less as well as the radiation of hot temperature to the underneath area. Conversely, much more heat absorbed by the concrete roof will radiate more intensely even when the sun has already set. This may cause a more electricity fee in regard to nighttime air conditioning or ventilating.

TOOLS USED FOR INSTALLATION

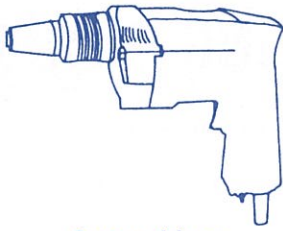

Screw driver



Hexagonal socket
Screw

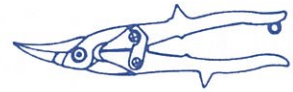

Metal snips

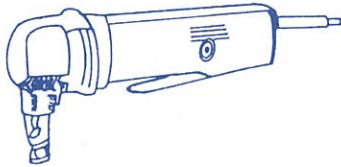

Nibbler

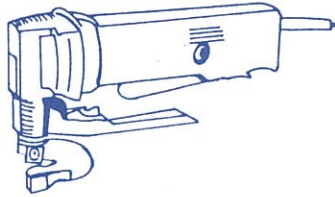

Hand shear

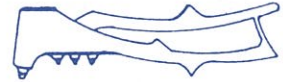

Reverter



Rubber hammer

COVERING AND OTHER ACCESSORIES



Rubber foam to be placed upon the wave



Rubber foam to be placed under the wave



Rubber foam to be placed under gable trim



Eave trim



Gable trim

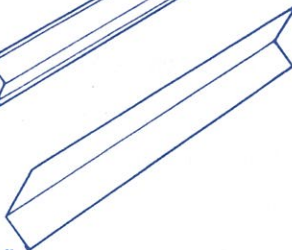

End wall flashing

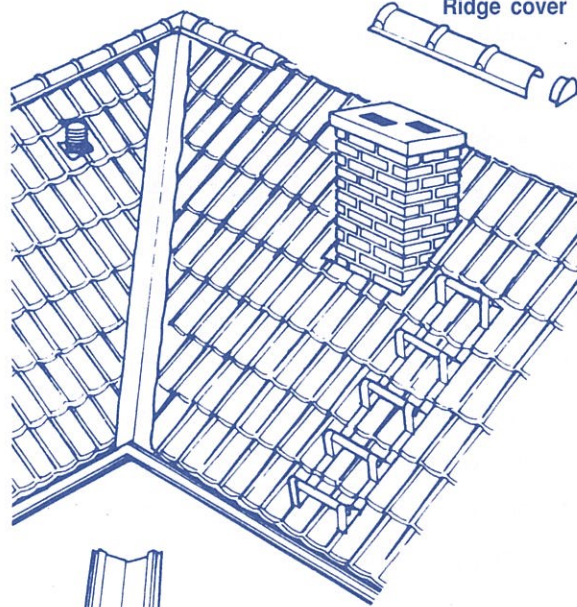

Ridge cover

Ridge cover end

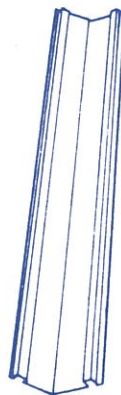

Valley gutter

GENERAL

GENERAL MATTERS

SCANROOF installation does not require any special working tools, the main equipments used are :

- Screw driver with adjustable speed and turning direction
- Metal snips
- Jig saw
- Nibbler shear the formed sheet

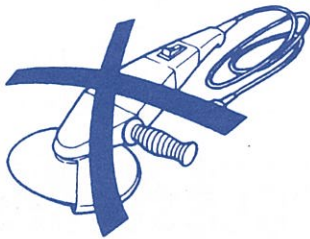

Do not :

Use a scrubber to cut Scanroof, for it will burn the coated color and the spark caused by the scrubber will damage its surface.

SPACE PREPARATION

Check for straightness of the roof framework, measure the oblique length of the roof framework, if they are unequal it is because of distorting or twisting, and should be corrected. However the laying of the first row of SCANROOF (the lowest) should be done alongside with the gable trim. Exceeding end of SCANROOF not more than 20-30 mm. in the direction of the gable can be disguised with gable trim.

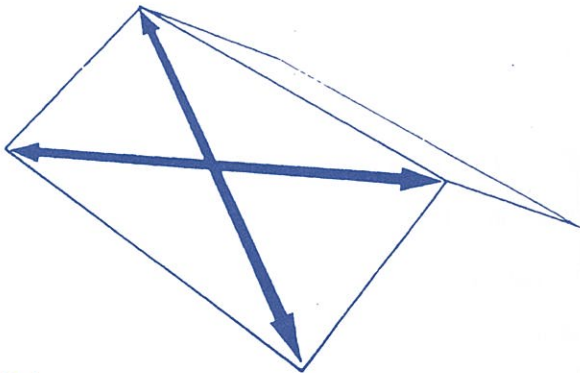

Note :

slope of the roof placed with SCANROOF should not be less than 12 degree.

SELF DRILLING SCREW

SCANROOF will be fastened with the roof framework or fixed to the others with self drilling screws which are specifically devised, along with their rubber rings.

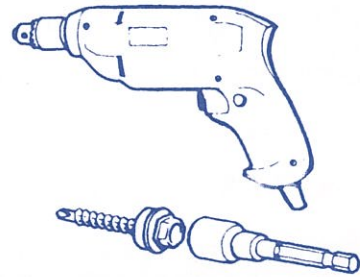

Caution :

When walking on SCANROOF, be sure to walk only the tiles' ralley.

SURFACE REPAIRING

Stains caused by scratch on SCANROOF are curable by way of repairing paint specially prepared by the company.

Metal dust or others made during installation should be removed once the work is done.

INSTALLATION OF SCANROOF

SCANROOF can be fixed upon almost every kind of roof framework, even the existing roof tile

New roof framework installation

The installation of SCANROOF on the new roof can be done on both iron and wooden framework which can either be supported by insulating layer or not. The space between rafters must not exceed 1500 mm.

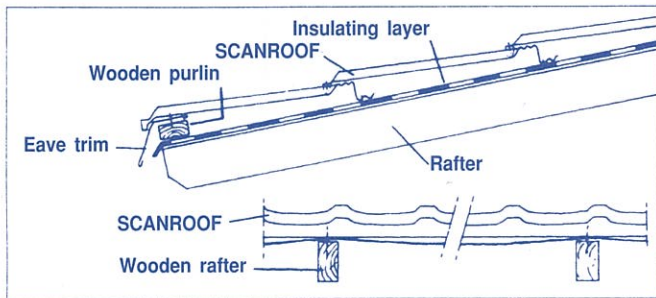

Old roof framework installation

The placement of SCANROOF on the old roof framework can be done by laying a piece of wood or formed steel sheet on the existing rooftop, in order to substitute rafters for SCANROOF without any necessity of reconstructing the whole roof

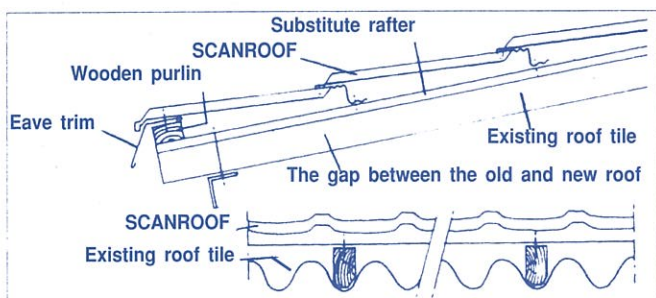

EXPANSION CAUSED BY HEAT

Since, there will be expansion caused by solar heat. Two solving methods are as follows:

Solution 1

Spare the space between SCANROOF for every connecting 15 meters of the roof and place a specially devised cover upon as displayed.

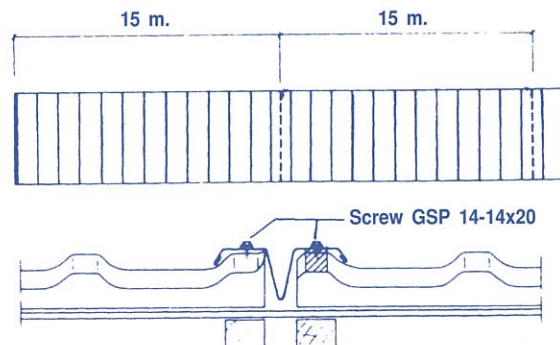

Solution 2

Use a specially devised iron clip to fix SCANROOF with the rafter instead of the drilling screw.

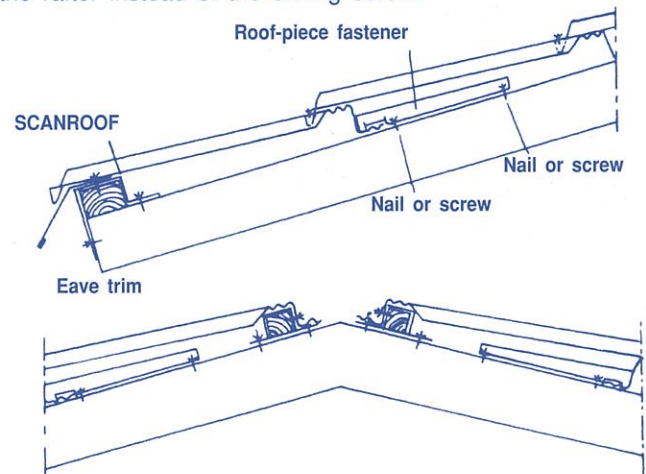

INSTALLATION METHOD

SCANROOF installation starts from the lowest row, say, at the roof rim by placing a 50 x 50 mm. Z-shaped iron tie to support the roof-piece's end, along with rain drain holder, rain drain or roof rim cover, then begin placing SCANROOF row after row

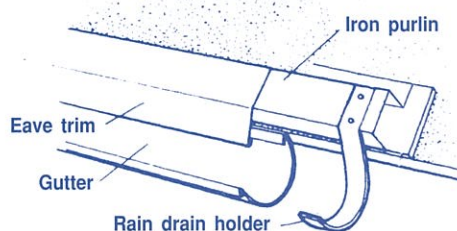

SCANROOF installation starts from the lowest row, from right to left, and must be paralleled to the roof eaves as much as possible, and in order to avoid the waste from roof-piece's end exceeding the gable's line which will increase in number along with the row of SCANROOF placed. The exceeding parts on the left side that were cut can be brought to start up the next row in the right

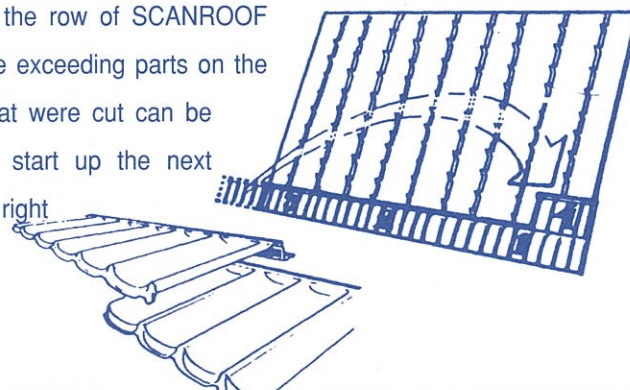

SCAFFOLD

For the building whose roof has a steep slope, the installing worker cannot stand on placed SCANROOF. In such case, the scaffold can be used to enable the more comfortable working. And when the job is completely done at the highest row, the scaffold can be dismantled and carry downward level by level to the roof rim without using any other aiding equipment.

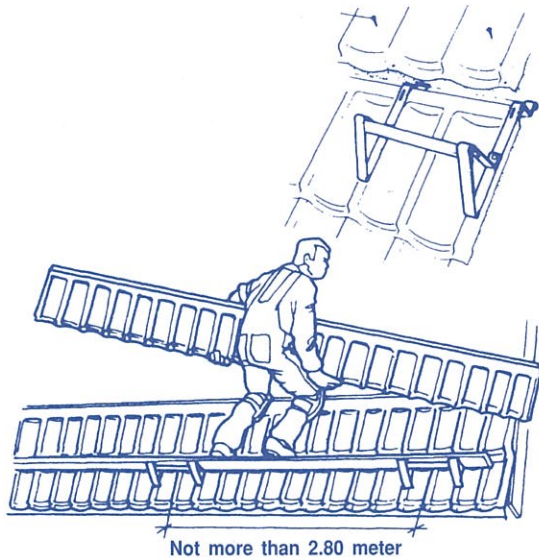

JOINT AT THE ROOF-PIECE'S END

The overlapping placing of SCANROOF on its end must be done for 1 piece, then fasten by using screw GSP 14-14 x 20 as displayed.

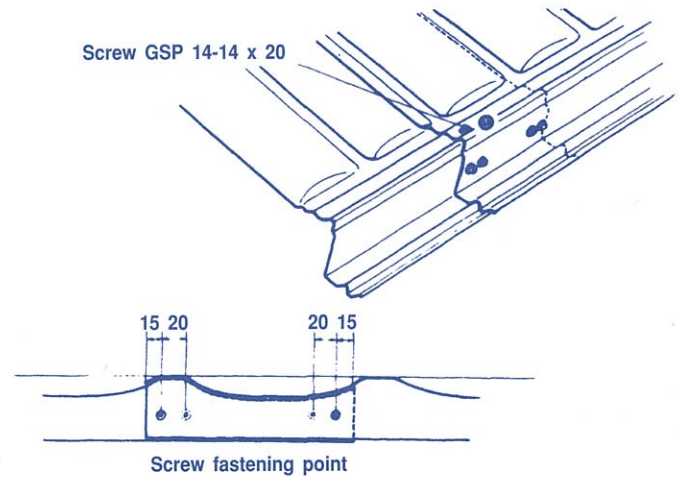

SCREW USED FOR THE ROOF-PIECE FASTENING

Sizes and kinds of the following screws are specially devised.

▶ Screw GSP 14-14 x 20, color-coated head, use for fastening the roof-piece's joint, overlapping area, and the gable's cover.

▶ Screw GSP 14-14 x 20, color-coated head, use for fastening the downward wave of the roof-piece in very 400 mm. of the first row or every other wave or the scaffold while working.

The fastening between rows of SCANROOF can be done with a number of screws GSP 14-14 x 20 in every 400 mm. (every other wave). It should be done on the top wave first, then fasten SCANROOF with the rafter by using screw G 10-16 x 16

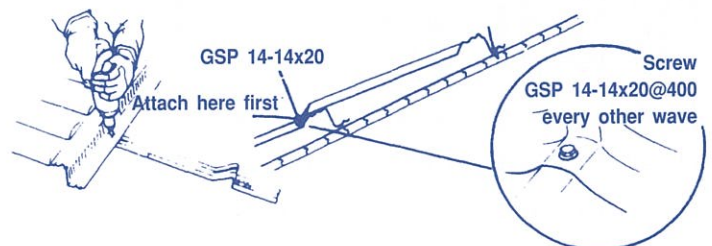
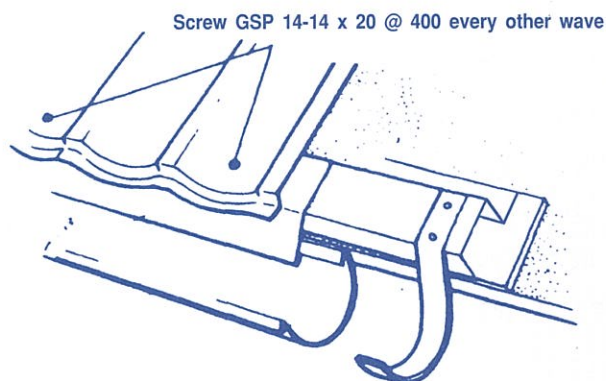

RIDGE COVER

Another advantage of SCANROOF is it allows an adjustment of length between the overlapping rows of roof-piece, so we can arrange the equal span of each row and this make no exceeding part on the top row before the ridge cover is placed or it can be placed as in normal 420 mm. overlapping and rearrange at the top row. In case there is space less than 270 mm. for the topmost row, the roof-piece should be cut along their length with the nibbler and the cut fragment should be placed under the roof-piece as shown in the picture.

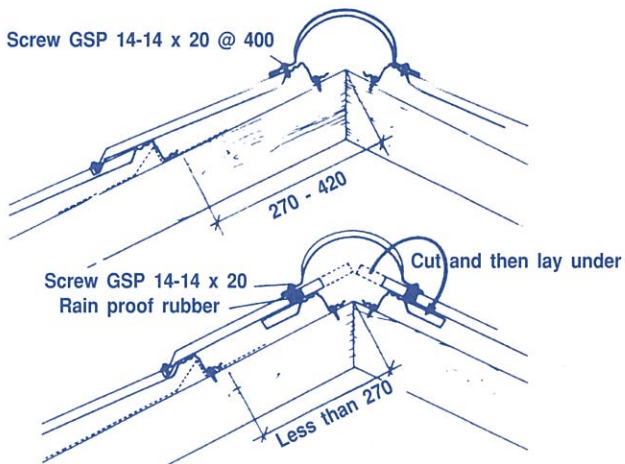

Rain proof rubber will be used only when SCANROOF is cut along its length, and in such case the ridge cover must be cut at its head as displayed in the picture.

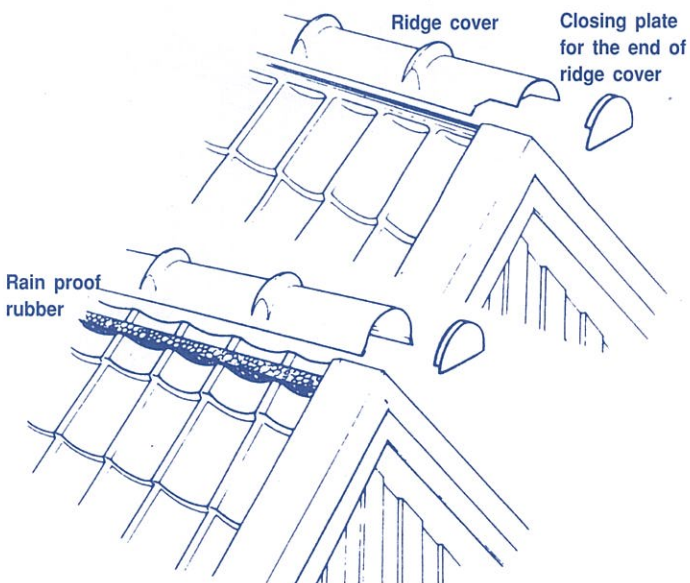

H I P S

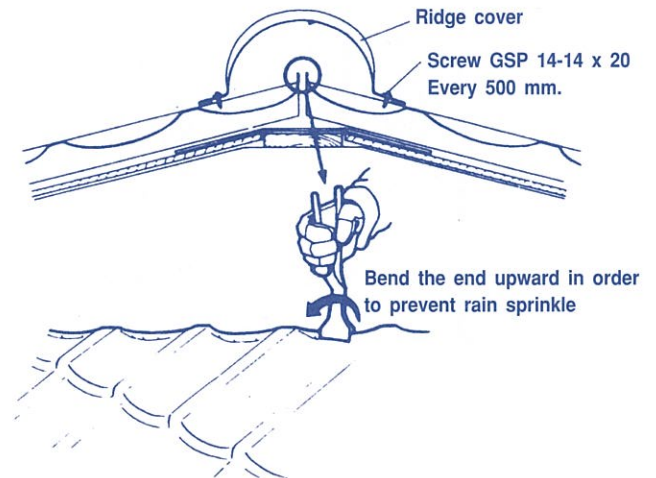

MANSARD ROOF

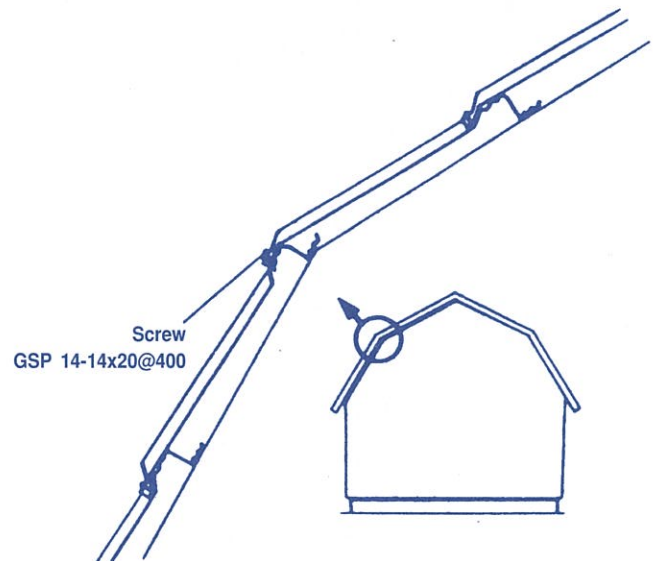

INSTALLATION OF THE GABLE TRIM

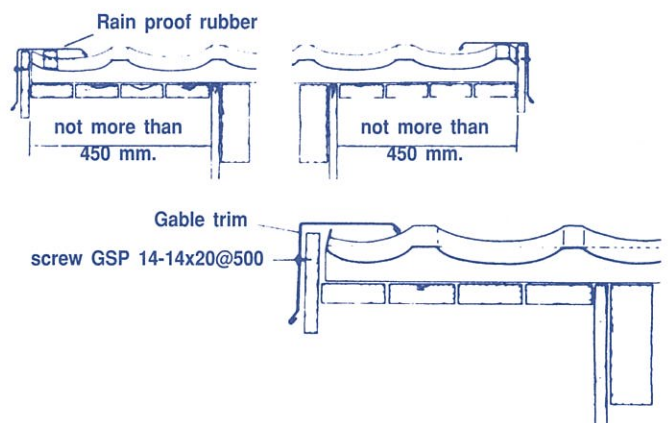

DETAILS WHEN THE ROOF-PIECES MEET THE WALL

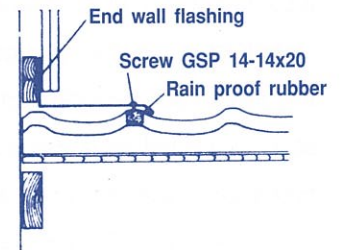
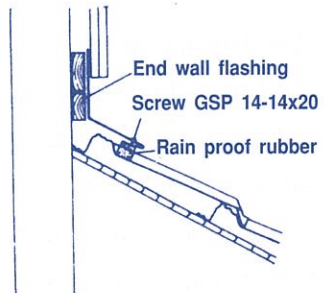
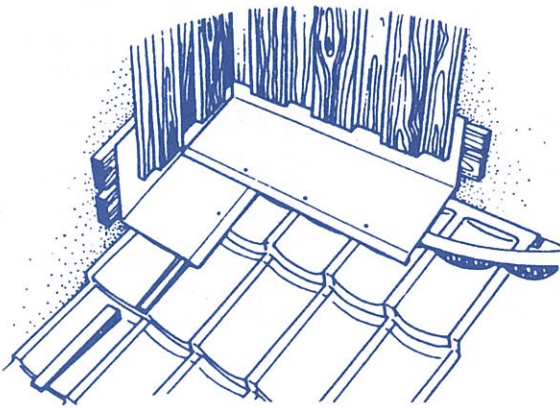

The end of roof-piece should be bent-up to prevent running back water.

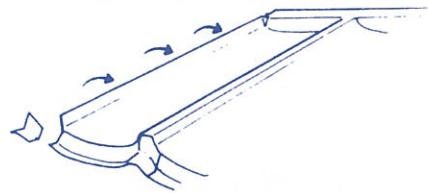

VALLEY GUTTER

Valley gutter should be placed with overlapping for at least 500 mm. See details of the installation in the picture.

Fastening with the wood-laid roof

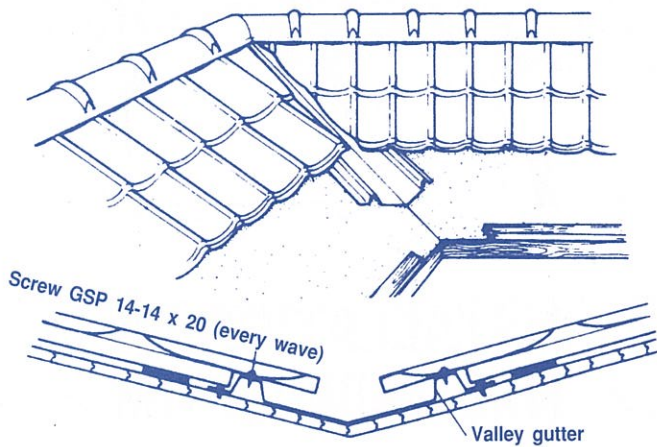

Fastening with the rafter

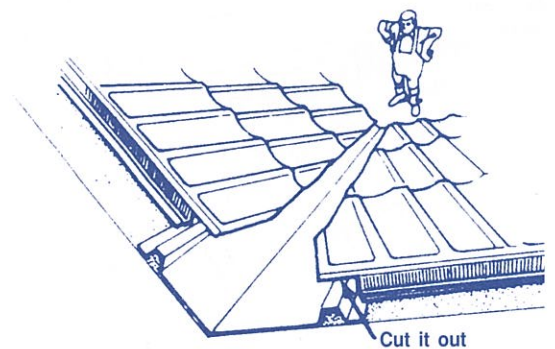
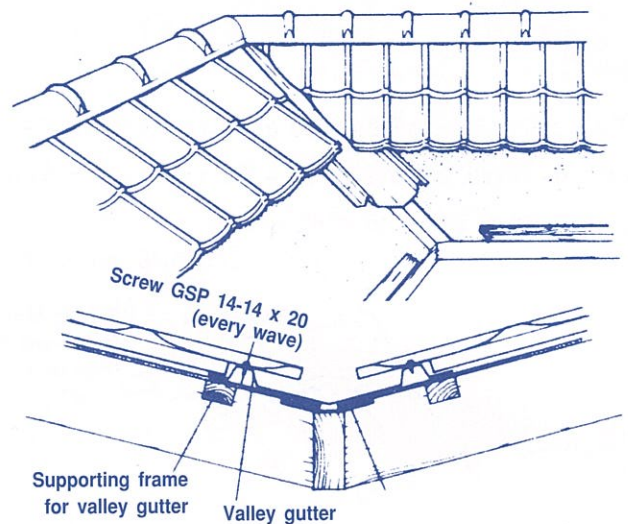

INSTALLATION OF RIDGE COVER AND EAVE TRIM

In case of the highest row is full

Place the first row (the lowest) of SCANROOF by letting its end to be exceeded the rafter's end for 5 cm.

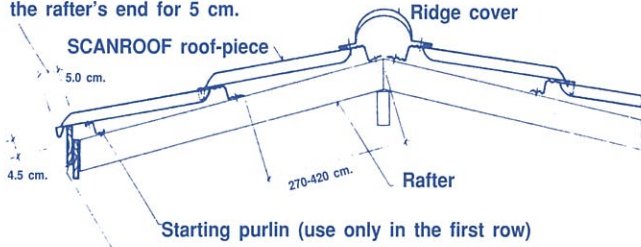

Place the roof rim's wood to be higher than behind the rafter for 4.5 cm.

In case of the highest row is not full

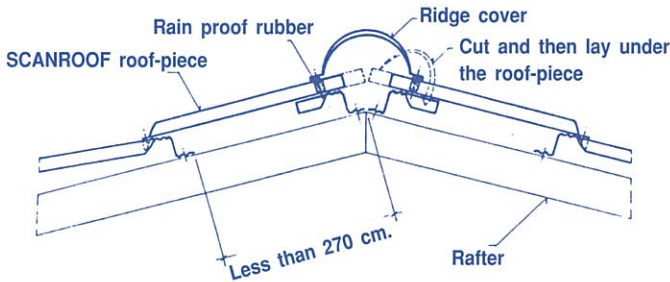

INSTALLATION OF GABLE APEX'S COVER

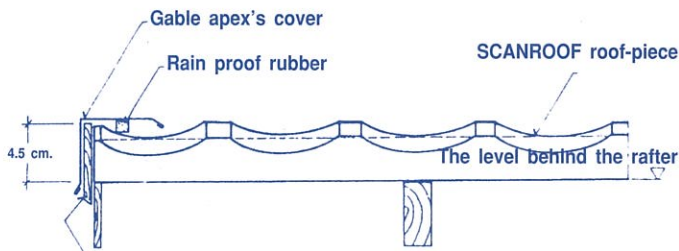

Place the gable apex's wood to be higher than behind the rafter for 4.5 cm.

SCANROOF UNDER CONCRETE COVER

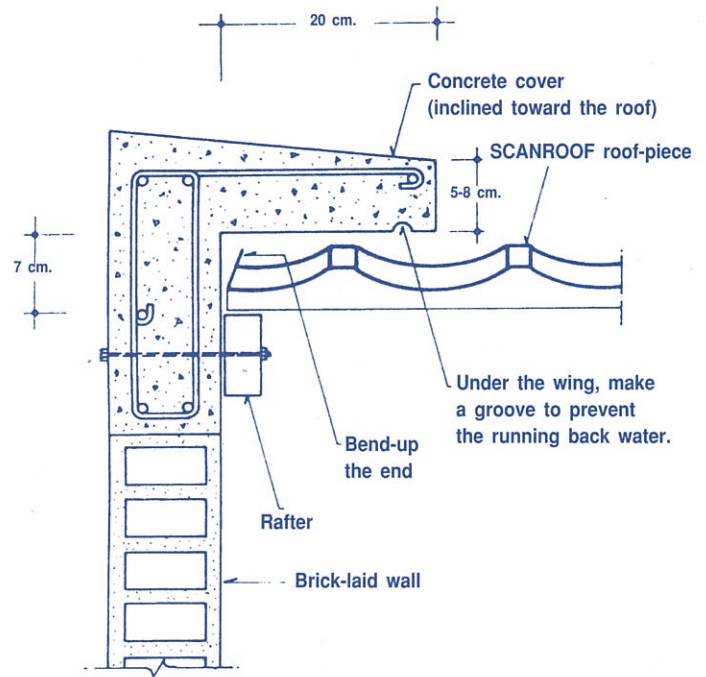
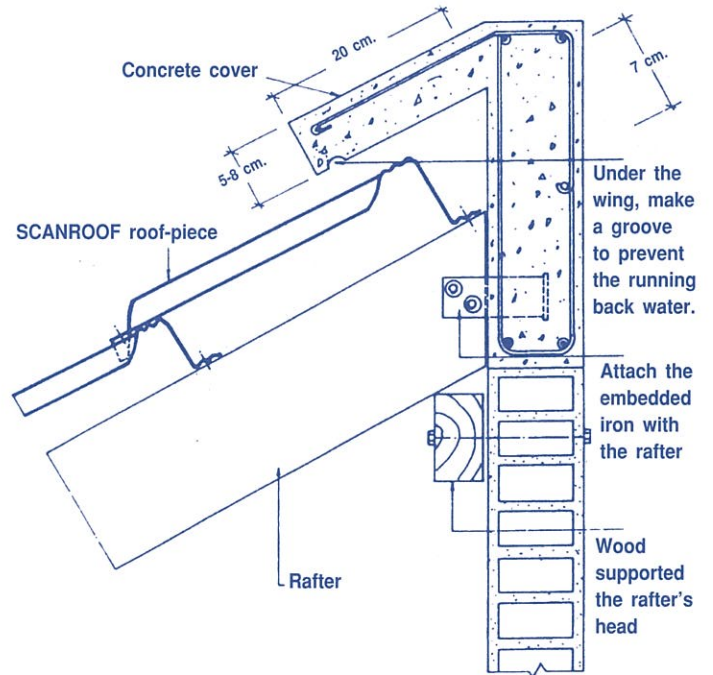

INSTALLATION OF END WALL FLASHING

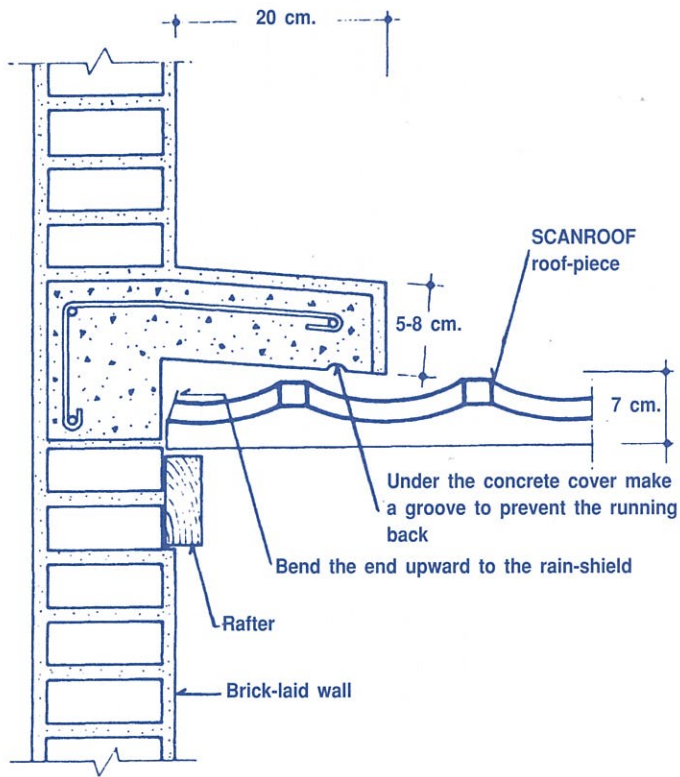

INSTALLATION AT SOME SPECIAL POINTS (MANSARD)

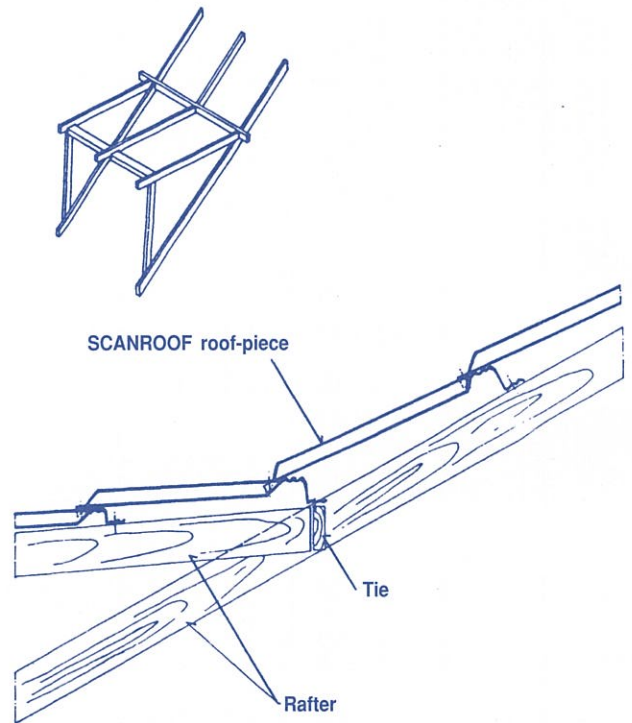

INSTALLATION OF COVER AT THE CHIMNEY OR AGAINST THE WALL

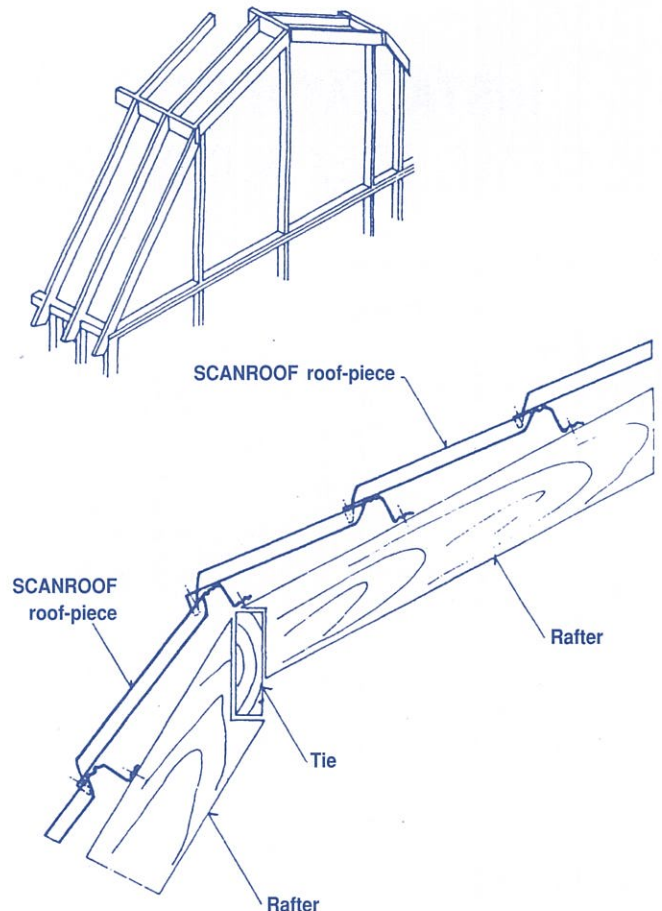
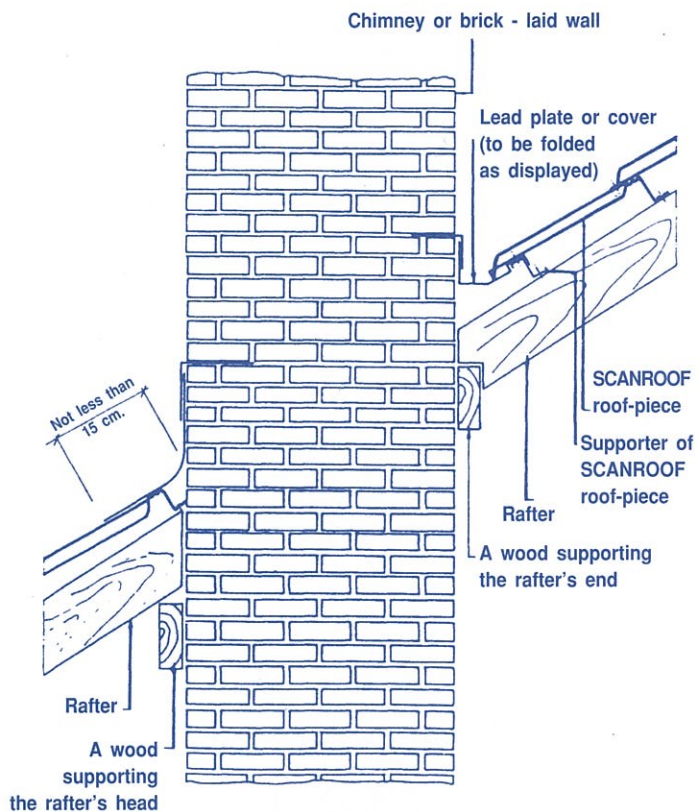

THE MAKING OF ROOF RIDGE

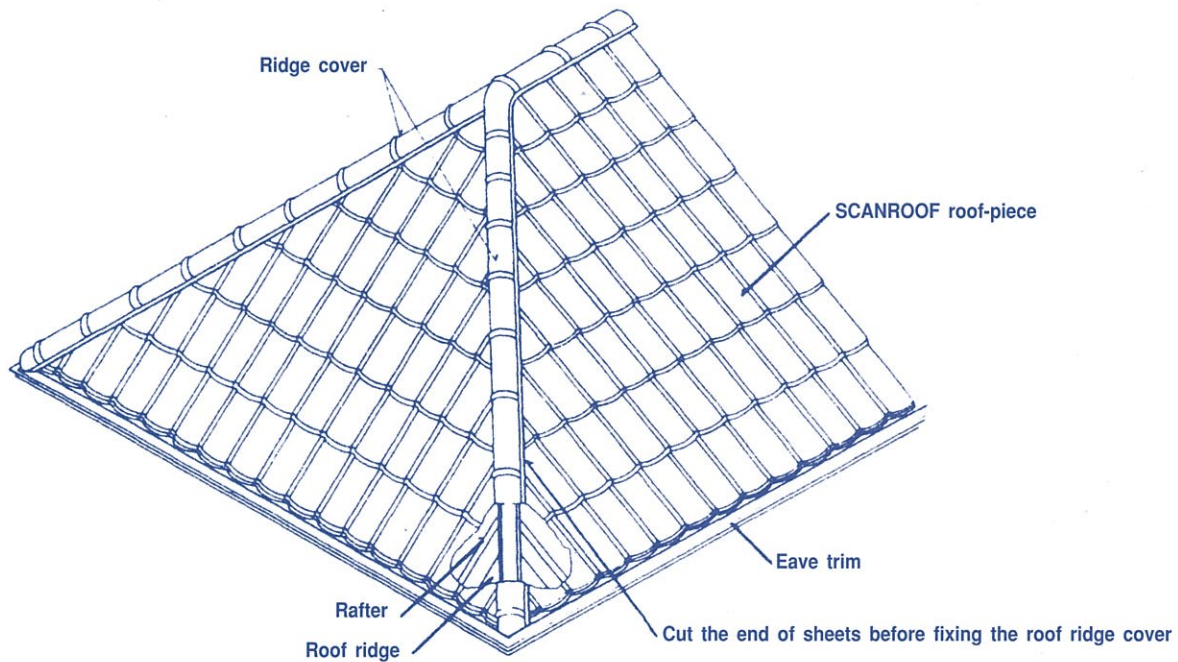

INSTALLATION OF ACRYLIC SCANROOF

The roof - piece must be fastened with a screw at every crest, be sure the acrylic SCANROOF is predrilled before screwing.

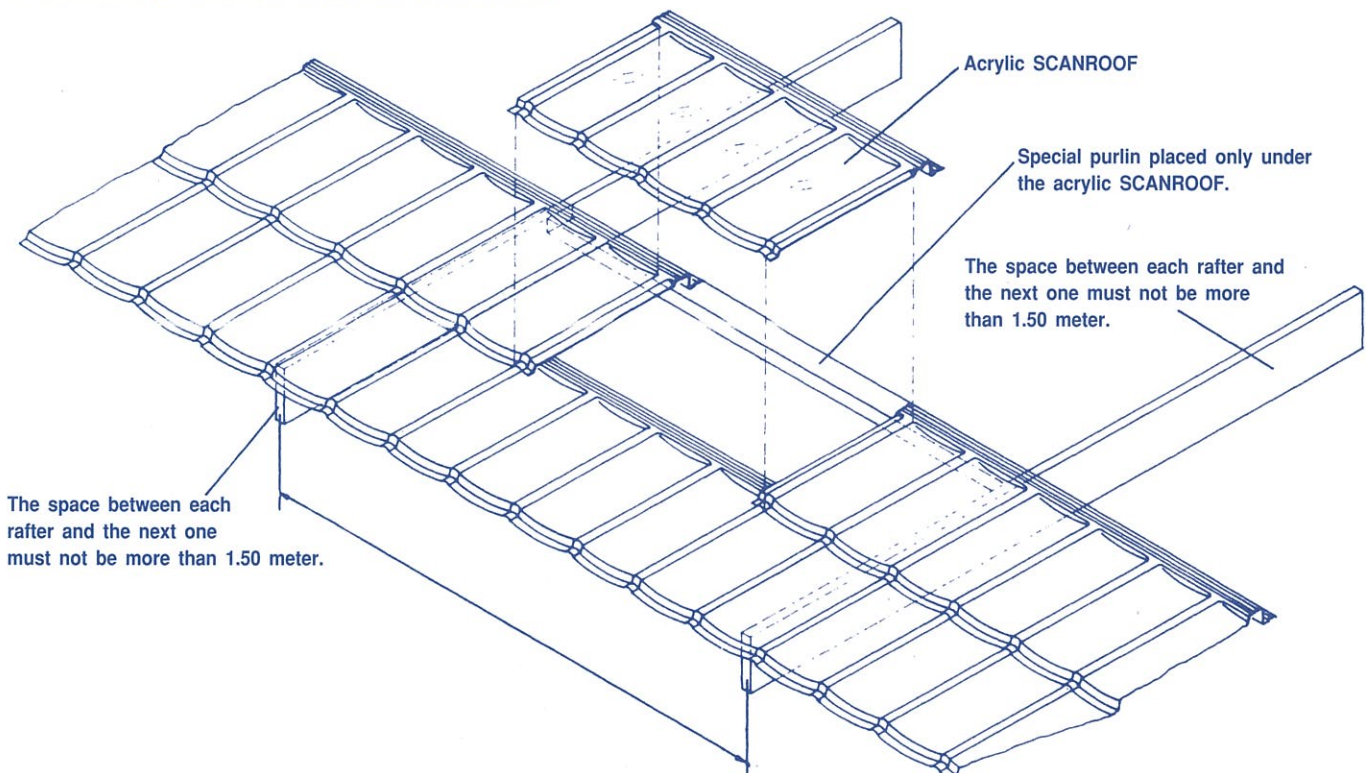

OTHER SPECIAL DETAILS

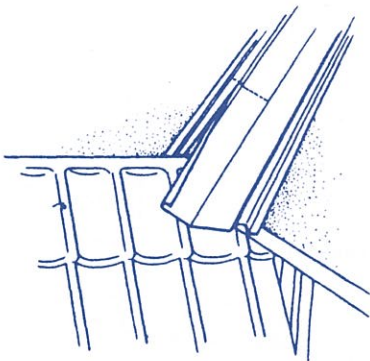

1. Cut the valley gutter

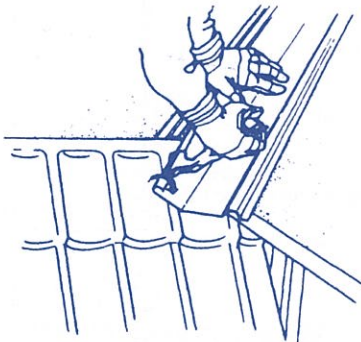
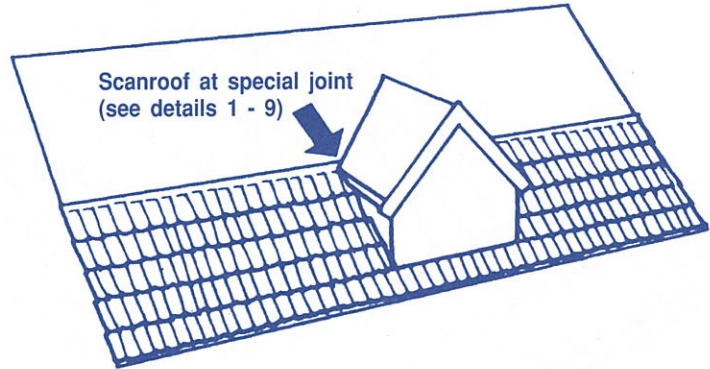

2. Fold the valley gutter upward

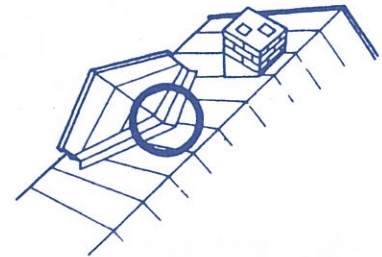

7. Join the valley gutter on the apex of the gable

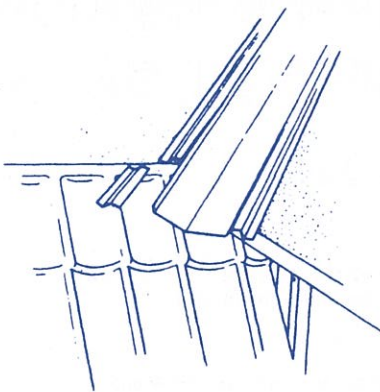

3. Check for the valley gutter fastening

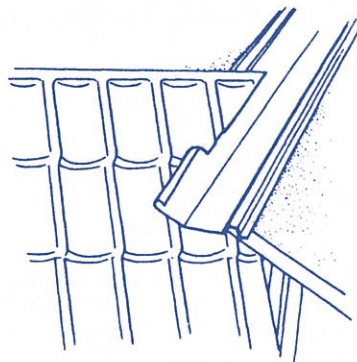

5. Install the cut SCANROOF

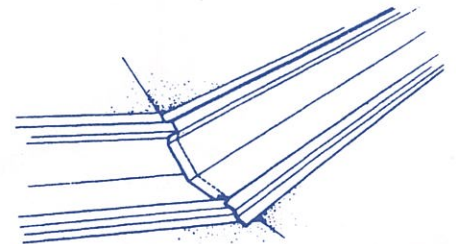

8. Join the valley gutter on both side of the gable

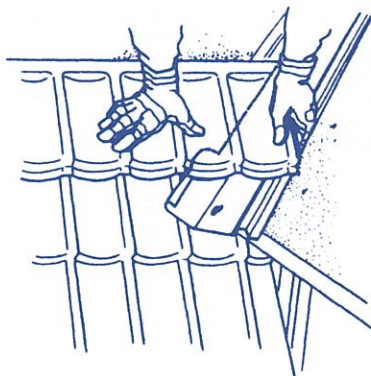

4. Mark the cut shape on the next row of SCANROOF

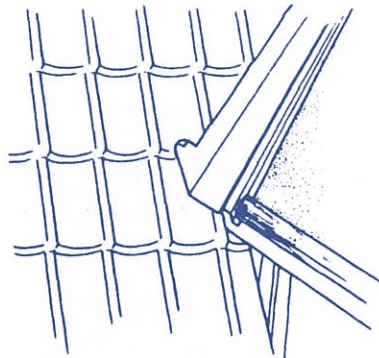

6. Trim the valley gutter end

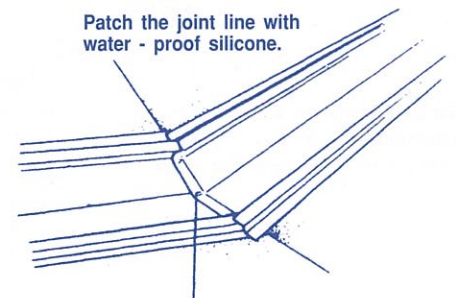

9. Bend the valley gutter end downward

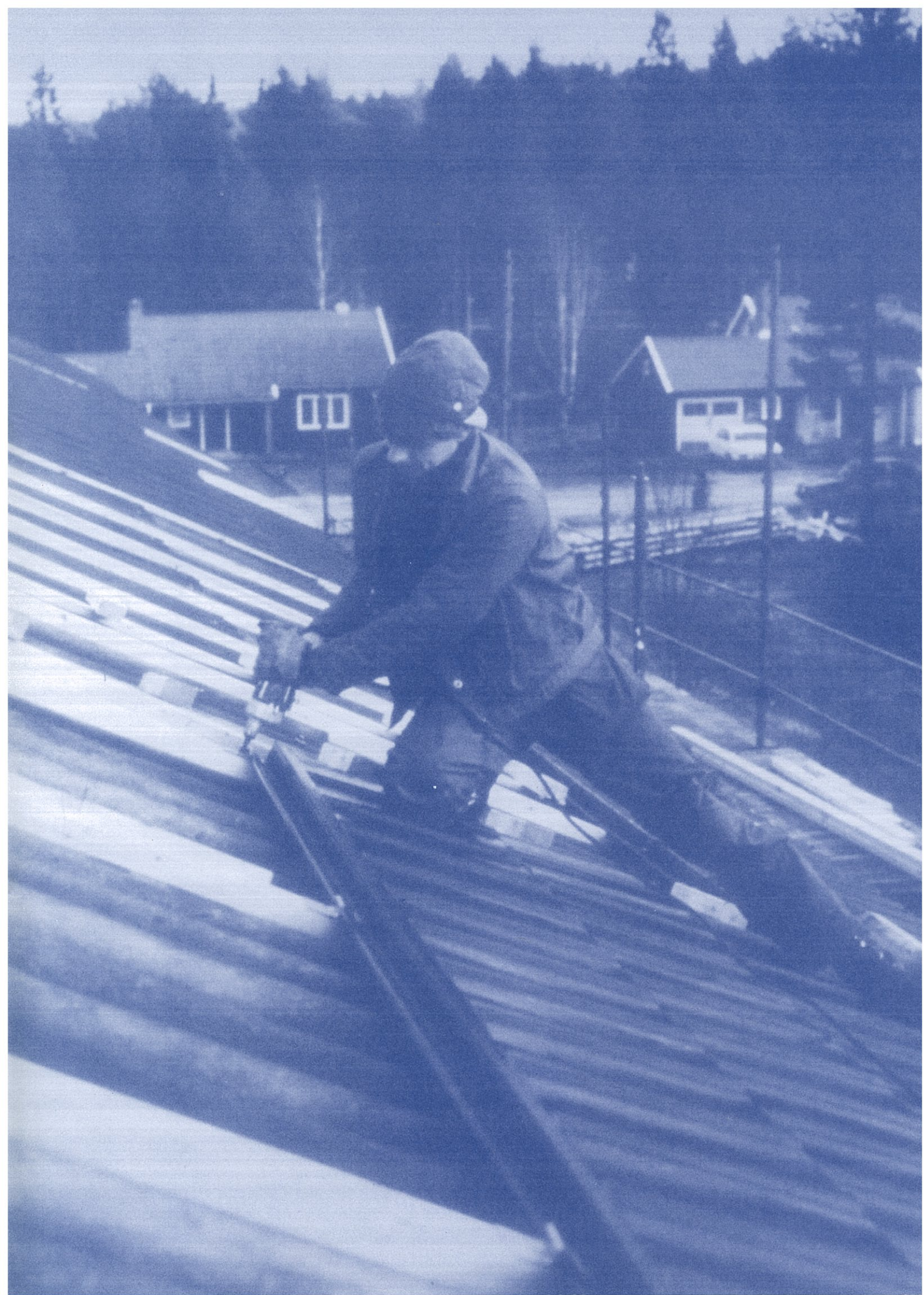



Bangkok Steel Industry Public Company Limited

27 Moo 10 Poochaosamingprai Road, Phrapradeng, Samuthprakarn 10130 Tel. 0-2754-4617-56 Fax. 0-2755-9063
<http://www.bangkoksteel.co.th>